

An Innovative Technology Company  
Providing Energy and Emission Reduction Solutions



# CoGeneration Solutions

Thermal Energy International



### Thermal Energy Combined Heat and Power (CHP), CoGeneration and TriGeneration Solution Benefits:

- Up to 70% electricity cost reduction (self-generated cost of \$0.04/kWh)
- Net project payback period typically 2 - 5 years
- Up to 93% energy conversion & utilization efficiency
- 10% to 20% additional savings through heat recovery from existing exhaust streams
- On site natural gas electricity generation

### Thermal Energy Cogeneration Solutions

Thermal Energy International (TEI) has over 25 years of unrivaled experience in successfully delivering complex heat and energy recovery projects globally in many different sectors.

CHP equipment is now commonplace, but the key to a successful CoGeneration project is in maximizing heat and energy recovery, which is no trivial task.

TEI will design and deliver CoGeneration / TriGeneration solutions with an energy efficiency of up to 93% while the industry average is only 65% to 75%.

### TEI Unique Approach: Customized for Your Specific Needs

We believe it is important to optimize and design a solution based on your project needs, requirements, and objectives, rather than to fit and design a project around a CHP plant.

TEI will optimize electrical operation and thermal balancing as a first priority. This makes our CoGeneration solutions more efficient, cost-effective, and profitable. Subsequently, the CHP plant is selected based on best in-class technology that meets the customer and project requirements and objectives.

Our goal is to provide our customers with the optimal CoGeneration solution that maximizes energy use and cost savings while meeting your environmental, financial, and project requirements. We will also work with you to select the best in-class, most cost-effective CHP plant with the best service plan and corrective maintenance plan.

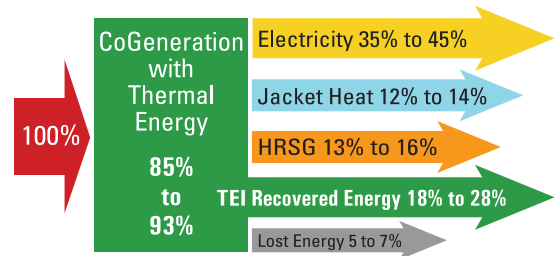
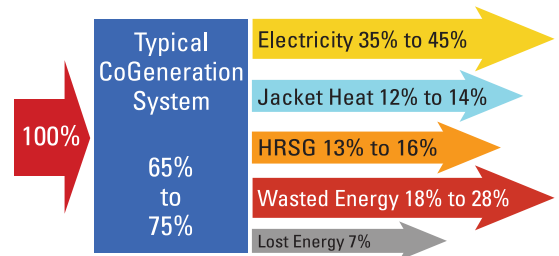

### CoGeneration Financial Benefits

Thermal Energy's CoGeneration solutions can provide up to 70% savings on electrical costs at a self-generated kWh cost of less than \$0.04/kWh, and an additional 10% to 20% natural gas energy savings from up to 90% recovery of heat losses from existing exhaust streams.

Thermal Energy's CoGeneration net project paybacks are typically less than 5 years with many commercial or industrial applications being less than 3 years.

### TriGeneration Solutions

Thermal Energy's solutions are not limited to the traditional CoGeneration system where only the electricity and heat are used.

Thermal Energy can also provide a TriGeneration solution that produces electricity, usable heat and chilled water. In the hotter periods of the year when the availability of heat sinks is diminished, energy from the CHP can be used to generate chilled water, thus offering additional energy savings.



Benefits of working with Thermal Energy International:

1. Over 25 years of unrivaled technology and services in energy recovery, conservation, and bioenergy solutions.
2. Global provider of energy efficiency and emission reduction solutions.
3. Turn key solutions with performance guarantees from design through to construction and commissioning, including performance management contracts.
4. Our solutions provide verifiable emission reduction credits (ERCs); and
5. Our solutions maximize total energy savings by economically optimizing and maximizing use of waste heat and energy.

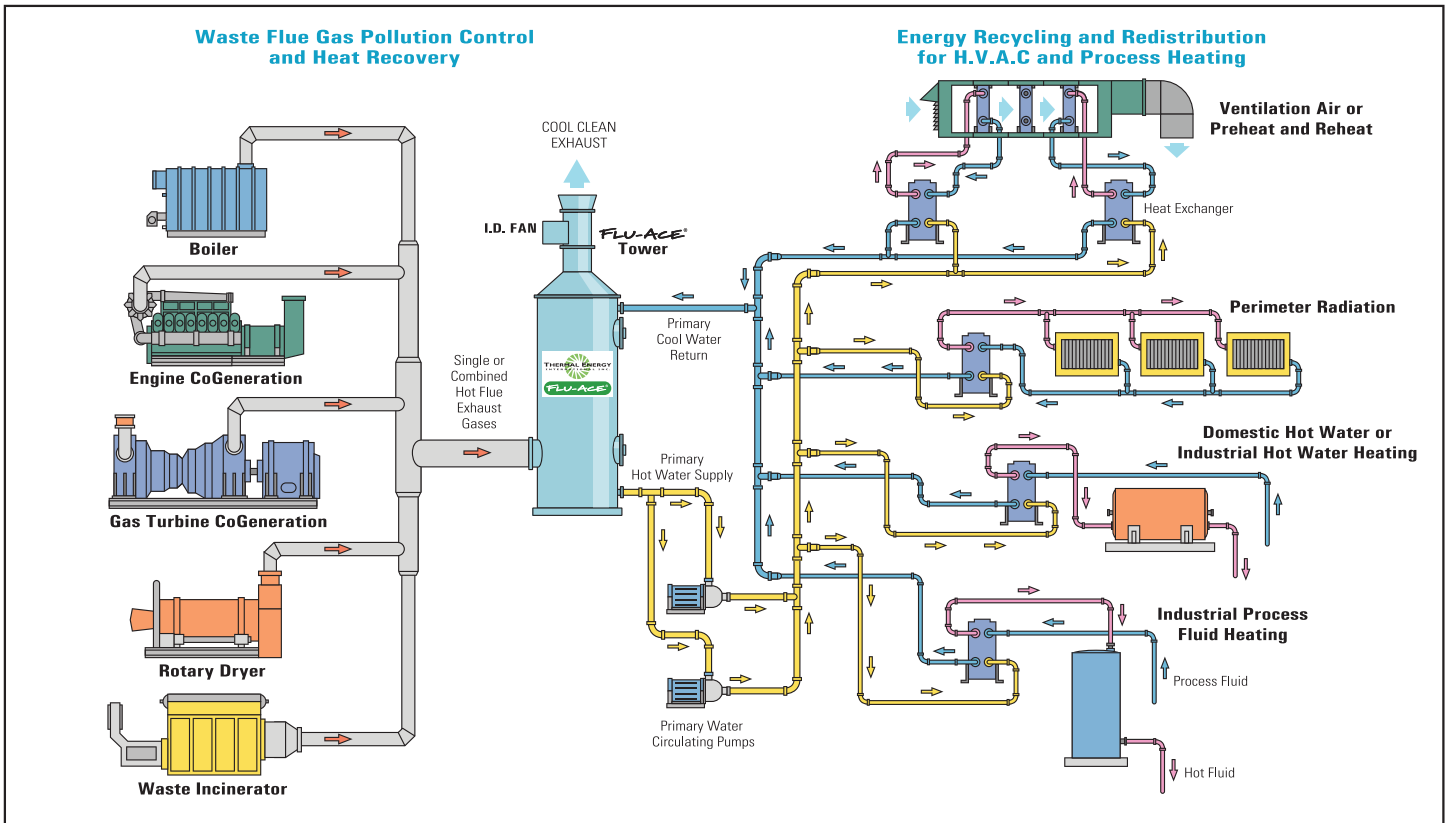

Proven Track Record of Successfully Delivered Global Turn-key Projects

TEI has successfully completed hundreds of complex turn-key heat recovery projects all over the world. From 2009 to 2015, In the UK alone, TEI successfully completed 24 projects resulting in savings 84,534,000KW of energy and £2,534,020 (British pounds):

Sample of TEI CoGeneration experience and successful projects:

Customer	Year	Installation	CHP Type	Energy Savings (MMBtu)	CO2 Savings (Tonnes)
St Vincent Hospital, Ottawa	1994	HRSG + FLU-ACE®	420KW Recip	25,500	1,346
Musgrave Park, Belfast	2009	CHP + FLU-ACE®	600KW Recip	4,600	243
Kings College, London	2010	Tri generation: HRSG & FLU-ACE® + AC	2MW + 2.4MW Recip	27,601	1,457
Salisbury Hospital, Salisbury	2011	CHP + FLU-ACE®	1.2 MW Recip	9,126	482
St. George, London	2011	HRSG + FLU-ACE®	5MW Turbine	45,334	2,393
Bristol Royal Infirmary, Bristol	2012	HRSG + FLU-ACE®	1.1 MW Recip	37,569	1,983
Chelsea and Westminster Hospital	2014	HRSG + FLU-ACE®	2 x 1.4MW Recip	11,007	581
Ballyrashane Creamery, N. Ireland	2016	CHP + FLU-ACE®	600KW Recip	11,202	591
Royal Stoke, Stratford	2016	CHP + FLU-ACE®	1MW Recip	New	New
Lesaffre, Italy	2016	HRSG + HHW + FLU-ACE®	4.4MW Turbine	New	New

## Thermal Energy: Supplying Innovative Award-Winning Energy Recovery, Conservation, Bioenergy and Emission Reduction Solutions

TEI is a full service, design-build firm with engineering accreditation, established in 1986. We have designed and built many energy and emission reduction solutions for our customers.

Our team of professionals is highly experienced in plant and process energy efficiency evaluations and innovative solution development. We conceptualize, design, manufacture and deliver custom solutions which reduce your energy costs, improve energy efficiency and reduce the environmental impact of your facility.

We pride ourselves on working with customers to gain an in-depth understanding of their business, corporate, social and fiscal challenges. With this sound footing, our team of professionals provides complete solutions from initial design concept to installation, to financing and servicing of varied technology solutions.

### Typical applications include:

- ▶ Waste energy recovery (FLU-ACE® and other);
- ▶ Biomass drying solutions (DRY-REX® and other);
- ▶ Steam and condensate system solutions (GEM® and other);
- ▶ CoGeneration & TriGeneration; and
- ▶ Burner/Boiler system improvements.

STOP delaying energy cost reduction programs and  
START saving by implementing our CoGeneration  
solutions with up to 98% efficiency.

Let us put our experience to work for you.

Contact TEI for a PES (Preliminary Engineering Study).

36 Bentley Avenue, Ottawa ON, Canada K2E 6T8  
E-mail: [sales@thermalenergy.com](mailto:sales@thermalenergy.com)  
Tel.: 613.723.6776 Fax: 613.723.7286

[www.thermalenergy.com](http://www.thermalenergy.com)

An Innovative Technology Company Providing  
Energy and Emission Reduction Solutions

